

2023

COPPER COUNTY

- 412A-A/B WALK/TROT 18 + UND
- 412A-A/B WALK/TROT 19 + OVER
- 413-WALK/TROT YTH 5-10
- 414-WALK/TROT YTH 11-18
- 415-WALK/TROT AMA
- 416-WALK/TROT AMA SPB

POR. SUU. JAN. 1

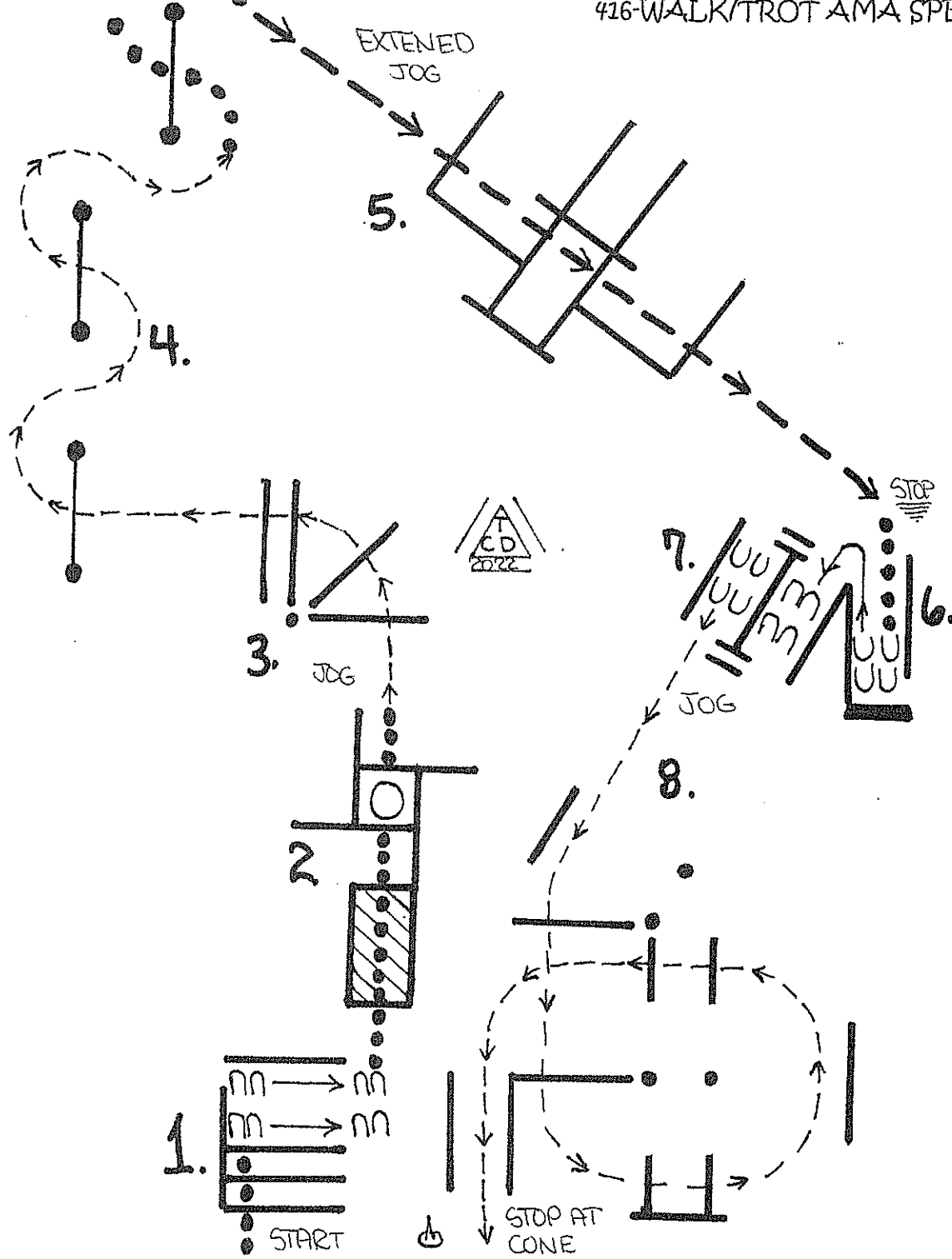

1. WALK OVER POLES INTO SIDE PASS BOX, SIDE PASS RIGHT WALK AWAY
2. WALK OVER BRIDGE & INTO BOX 360 EITHER WAY WALK OUT
3. JOG OVER 4 POLES
4. JOG THRU SERPENTINE & OVER POLES, BREAK TO WALK & WALK OVER LAST POLE
5. EXTENED JOG OVER 4 POLES STOP AT CHUTE
6. WALK IN CHUTE, BACK THRU POLES TO GATE
7. GATE:(LH) RIDE THRU CLOSE
8. JOG OVER 6 POLES STOP AT CONE

2023

COPPER COUNTY

POR. SUN. JAN. 1

417A- A/B OPEN

418-GREEN HORSE

419N-NSBA GREEN HORSE

420-NOV YTH

421-NOV AMA

422N-NSBA NOV AMA

423-JUNIOR HORSE

424N-NSBA JR HORSE

426-AMA SPB ALL AGES

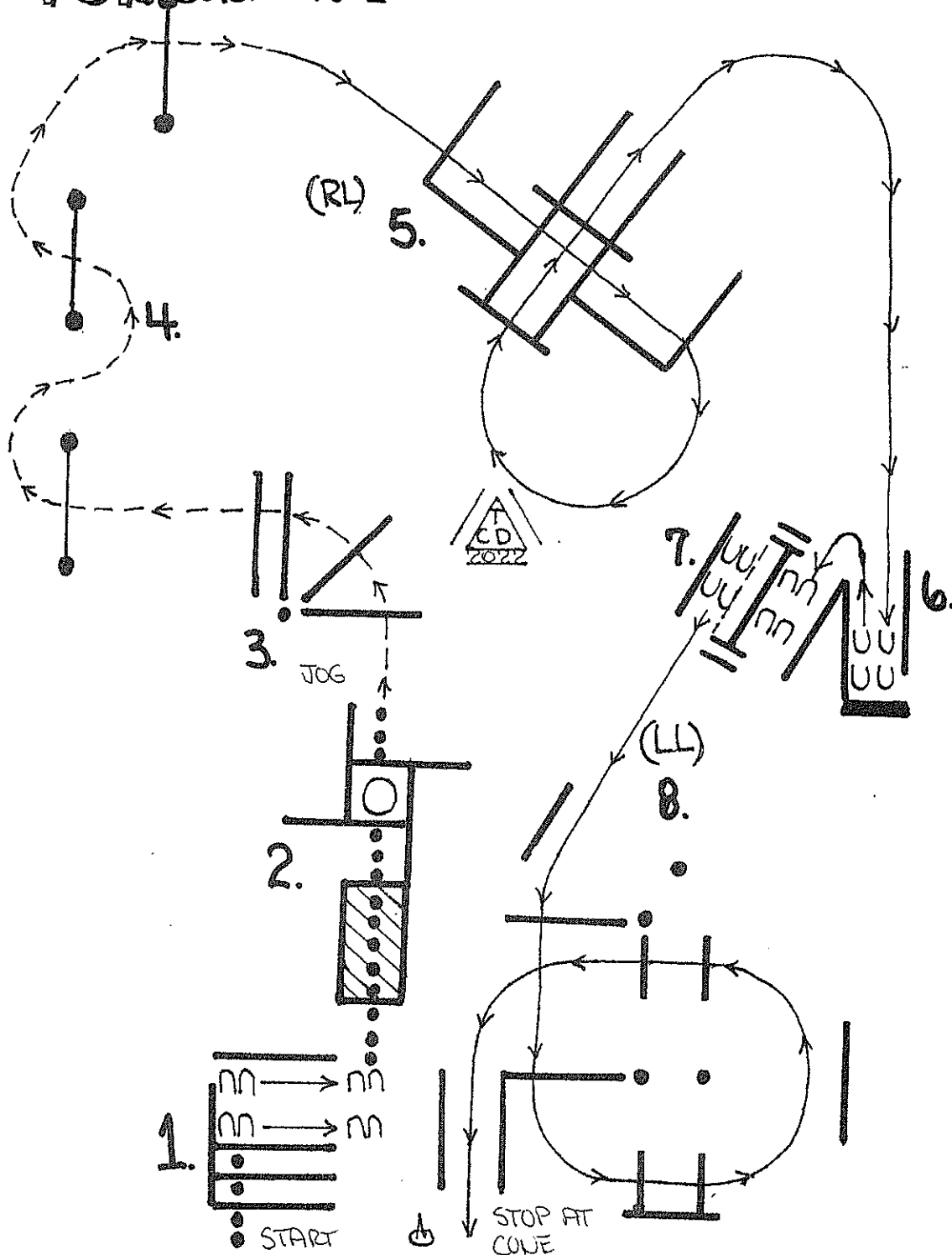

1. WALK OVER POLES INTO SIDE PASS BOX, SIDE PASS RIGHT WALK AWAY
2. WALK OVER BRIDGE & INTO BOX 360 EITHER WAY WALK OUT
3. JOG OVER POLES
4. JOG THRU SERPENTINE & OVER POLES
5. LOPE OVER POLES (RL) & INTO CHUTE
6. BACK THRU POLES TO GATE
7. GATE:(LH) RIDE THRU OVER POLE CLOSE
8. LOPE OVER POLES (LL) STOP AT CONE

2023

COPPER COUNTY

427-SPB OPEN

428-YTH 18 + UND SPB

429-YTH 13 + UND

430-YTH 18 + UND

431-AMA ALL AGES

432N NSBA AMA ALL AGES

POB SUN. JAN. 1

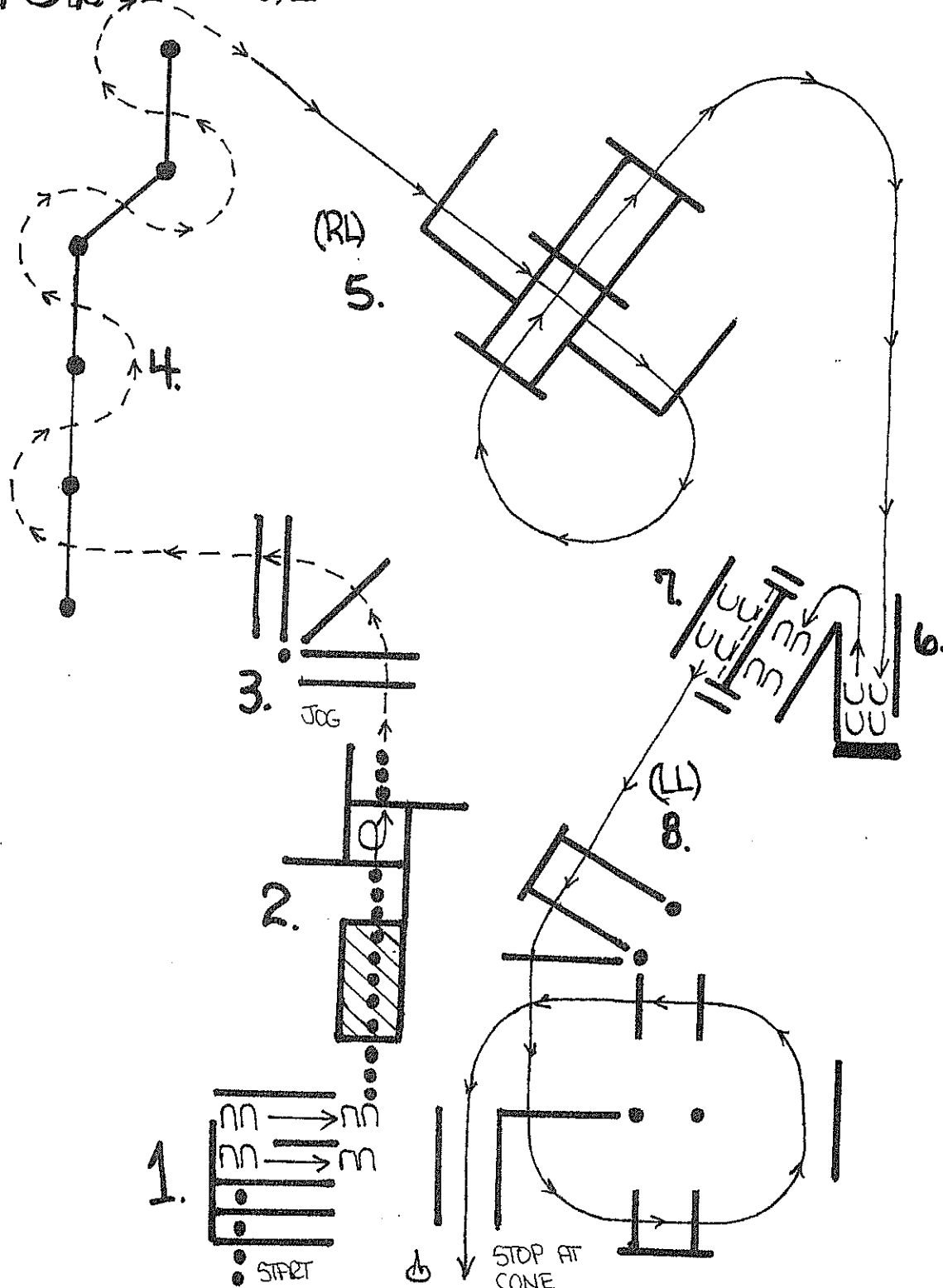

1. WALK OVER POLES INTO SIDE PASS BOX, SIDE PASS RIGHT OVER POLE WALK AWAY
2. WALK OVER BRIDGE & INTO BOX 360 LEFT WALK OUT
3. JOG OVER POLES
4. JOG THRU SERPENTINE & OVER POLES
5. LOPE OVER POLES (RL) & INTO CHUTE
6. BACK THRU POLES TO GATE
7. GATE:(LH) RIDE THRU OVER POLE CLOSE
8. LOPE OVER POLES (LL) STOP AT CONE

2023

COPPER COUNTY

PO R SUU. JAN. 1

434-AMA MASTERS 45 + OVER

435N-NSBA AMA 45 + OVER

436-SENIOR HORSE

437N-NSBA SENIOR HORSE

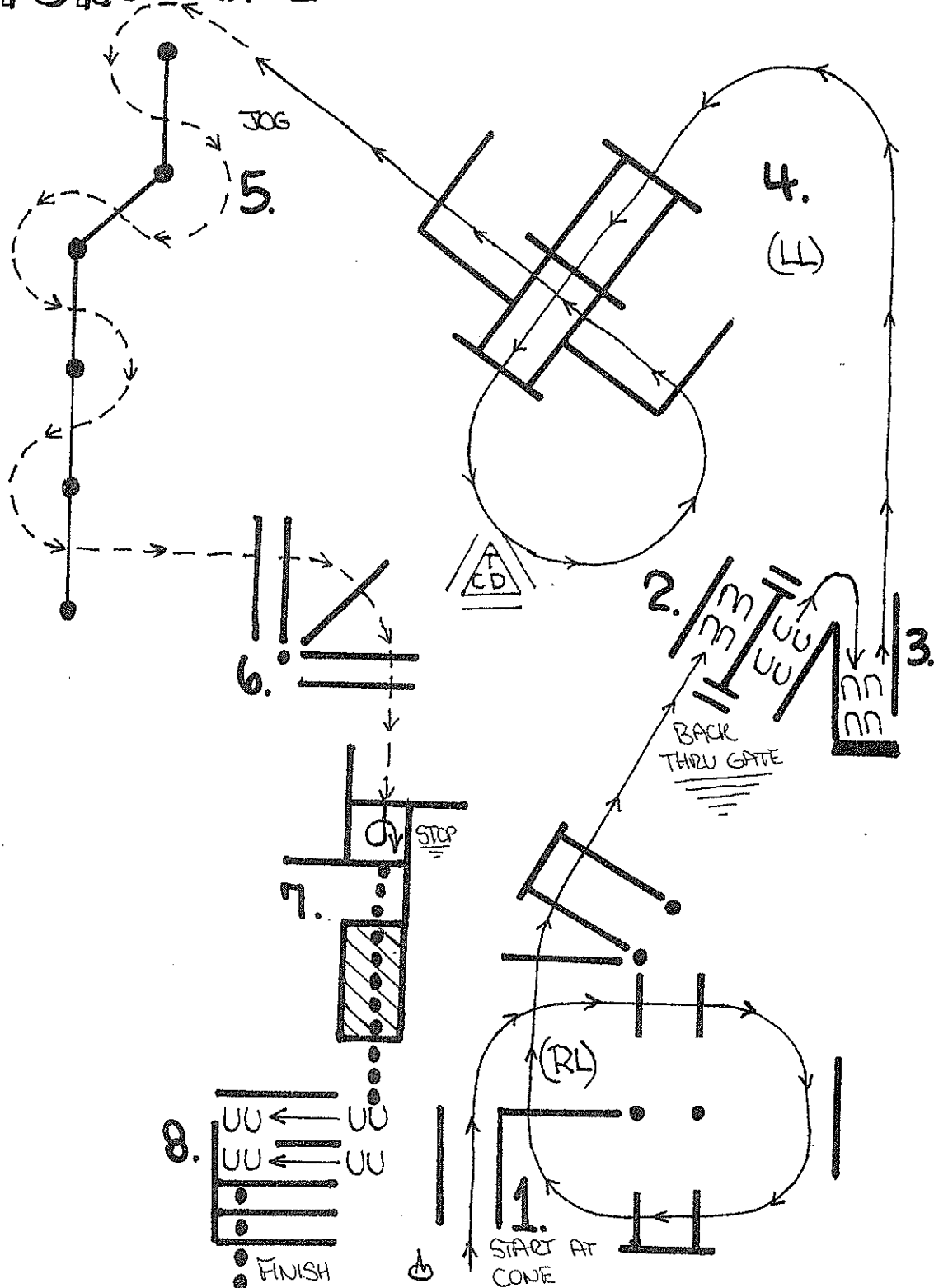

1. LOPE OVER POLES (RL) TO GATE
2. GATE:(RH) BACK THRU CLOSE
3. BACK THRU POLES & LOPE OUT OF WHITE (LL)
4. LOPE OVER POLES (LL)
5. JOG THRU SERPENTINE & OVER POLES
6. JOG OVER POLES INTO BOX STOP
7. 360 RIGHT & WALK OUT OVER BRIDGE TO SIDE PASS
8. SIDE PASS RIGHT OVER POLE & WALK OUT OVER POLES